

OPERATOR'S MANUAL

WITH PARTS LIST

EDGER/TRIMMER

- Specifications
- Operating Instructions
- Maintenance Information



MCLANE

MANUFACTURING
INC.

7110 East Rosecrans Ave.
Paramount, CA 90723
Telephone
(562) 633-8158 (323) 636-8336

CONTENTS

| | Page | | Page |
|-------------------------------------|------|---------------------------------------|-------|
| General Safety Suggestion | | Correct Edger-Trimmer Usage | 6 |
| | | Operation of the Edger-Trimmer | 6 |
| | | Maintaining Your Edger-Trimmer | 7 |
| | | Maintenance Check List | 7 |
| | | Engine | 7 |
| | | Oil Quality | 7 |
| | | Oil Level | 7 |
| | | Oil Changes | 7 |
| | | Spark Plug | 7 |
| | | Blade Maintenance | 7 |
| | | Blade Change | 7 |
| | | Lubrication | 7 |
| | | Storage Instructions | 12 |
| | | Maintenance Notes | 12-13 |
| | | Trouble Shooting Check List | 11 |
| Warranty | 6 | | |
| Parts Illustration | 8 | | |
| Parts List | 9&10 | | |
| Edger Trimmer Features | 2 | | |
| Assembly | 3 | | |
| Attaching the Handle | 3 | | |
| Installing Throttle Wire | 3 | | |
| Fill Engine With Oil | 3 | | |
| Operating Your Edger-Trimmer | 4 | | |
| Correct Engine Operation | 4 | | |
| Fuel Specification | 3 | | |
| Oil Specification | 3 | | |
| Starting The Engine | 4 | | |
| Engaging Drive Belt | 4 | | |
| Stopping The Engine | 4 | | |



CAUTION



This symbol marks important instructions relating to your personal safety. To avoid the possibility of injury, read and follow such instructions carefully.

When the manual refers to the left or right side of the edger-trimmer, it means your left and right when standing in the operating position.

GENERAL SAFETY SUGGESTIONS

Recommended by Outdoor Power Equipment Institute

DO NOT MODIFY EDGER-TRIMMER

Unauthorized modification to the edger-trimmer may impair its function and safety and affect edger-trimmer life.

Training

1. Read the Operating and Maintenance Instruction Manual carefully. Be thoroughly familiar with the controls and proper use of the equipment.
2. Never allow children to operate edger-trimmer.
3. Keep area of operation clear of all persons, particularly small children and pets.
4. Thoroughly train anyone using the edger-trimmer. Make sure all edger-trimmer operators know the safety, operating and maintenance procedures.

Preparation

1. Thoroughly inspect the area where edger-trimmer is to be used, and remove all stones, sticks, wire, bones and other foreign objects which might be picked up and thrown.
2. Do not operate edger-trimmer when barefoot or wearing open sandals. Always wear substantial foot wear, and pants or slacks that cover your legs when operating edger-trimmer.
3. Check fuel before starting engine. Do not fill gasoline tank indoors, when engine is running, or while engine is still hot. Clean off any spilled gasoline before starting engine.
4. Disengage cutterhead drive before starting engine.
5. Do not use edger-trimmer unless blade guard, belt guards and debris guard are properly in place.
6. Edge or trim only in daylight or in good artificial light.
7. Never operate equipment in wet grass. Always be sure of your footing. Keep a firm hold on the handle and walk, never run.

Operation

1. Start the engine carefully. Keep hands and feet well away from blade.
2. Do not change engine governor setting or over-speed engine.
3. Wear safety glasses when operating edger-trimmer.
4. Keep clear of discharge opening at all times. Never direct discharge of any material toward bystanders nor allow anyone near machine while it is in operation.
5. Stop blade when crossing gravel drive, walks or roads.
6. After striking a foreign object, stop the engine and inspect edger-trimmer for damage. Repair damage before starting engine.
7. Avoid loss of control or tipping on slopes and sharp corners by reducing speed.
8. If edger-trimmer should start to vibrate abnormally, stop the engine and check for the cause. Vibration is generally a warning of trouble.
9. Stop the engine whenever you leave the edger-trimmer, and when making repairs or inspections.

10. When repairing or inspecting make certain blade and all moving parts have stopped. Disconnect spark plug wire and keep wire away from plug to prevent accidental starting.
11. Do not run engine indoors.
12. Shut engine off and wait until blade comes to a complete stop before removing grass that may clog blade guard.
13. Watch out for traffic when working near roadways.
14. Stay alert for uneven sidewalks, holes in terrain or other hidden hazards when using edger-trimmer. Always push slowly over rough ground.
15. Remember, never operate edger-trimmer unless blade guard, belt guards and debris guard are properly in place.
16. Disengage power to cutterhead and stop engine before leaving edger-trimmer, before making repairs, inspections or adjustments, and when transporting or not in use.

Maintenance and Storage

1. Check blade mounting nut frequently for proper tightness.
2. Keep all nuts, bolts and screws tight to be sure equipment is in safe working condition.
3. Never store edger-trimmer with gasoline in the tank in a building where fumes may reach an open flame or spark. Be sure engine has cooled before storing in any enclosure.
4. To reduce fire hazard, keep engine free of grass, leaves or excessive grease.
5. After operating engine, never touch exhaust muffler until it has cooled completely.
6. Keep edger-trimmer in good operating condition and keep safety devices in place.

**TO AVOID INJURY**

READ OPERATOR'S MANUAL • KNOW LOCATION & FUNCTION OF CONTROLS • MAINTAIN SAFETY DEVICES • REMOVE POTENTIAL THROWN OBJECTS • NEVER EDGE OR TRIM NEAR PEOPLE • NEVER CARRY PASSENGERS • LOOK BEFORE BACKING • AVOID SLIPPERY OR STEEP AREAS • STOP BLADE & BACK SLOWLY IF MACHINE STOPS • AVOID BLADE UNLESS BLADE & ENGINE ARE STOPPED.

EDGER-TRIMMER FEATURES

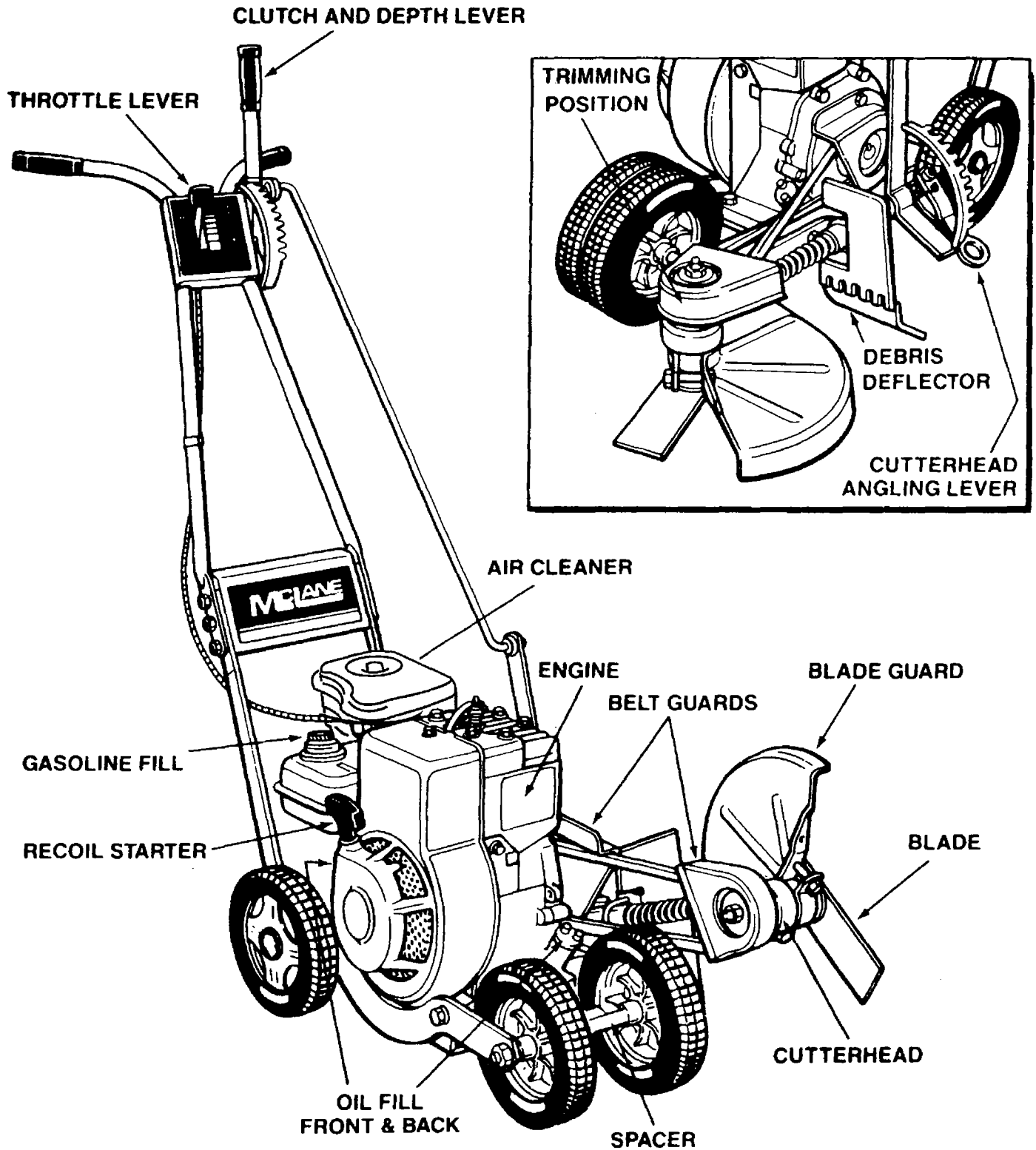

ASSEMBLY

TOOLS REQUIRED: 7/16" Wrench, Pliers, Screwdriver

NOTE: Reference to Left or Right side of machine is from the operator's position at the handle, facing forward.

The lawn edger, except the handle and throttle control, is fully assembled, packed and shipped in one container.

ATTACHING THE HANDLE

1. Remove handle brace, nuts, and bolts. Align the handle, lower support, and handle brace holes. Use all six nuts and bolts. Leave bolts loose until Steps 2 and 3 are completed (Fig. 1).
2. Install control rod into upper and lower pivot holes and secure with cotter pins (fig. 1). Oil pivots lightly before installing rod.
3. Move clutch-depth lever into rear notch of quadrant on handlebars. Move cutterhead angling lever to top notch of quadrant.
4. Remove spark plug wire from spark plug. Move throttle to **OFF** position. Check clutch operation by pulling recoil starter rope. If blade turns when depth lever is in top notch, loosen handle bolts and pull towards operator. Snug bolts and check clutch operation again.
5. Slip on the handle grips

— IMPORTANT NOTE —

Make sure blade does not turn when lever is in top notch — disengaged.

Tighten bolts.

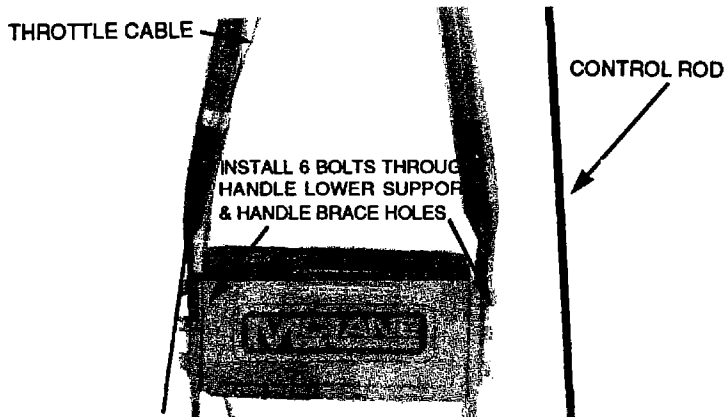

THROTTLE CABLE CLIP

FIG. 1

FILL ENGINE WITH OIL

NOTE: There is no oil in engine crankcase.

1. Follow Instructions in the engine manual for correct grade of oil, oil filling, and oil changing.
2. Do not mix oil with gasoline.

INSTALLING THE THROTTLE WIRE

1. If the throttle cable is not attached to the engine carburetor, follow the instructions in the engine operating manual. Some throttle cables can not be attached before shipping

Check oil level of engine every time edger-trimmer is used. An improper oil level can cause extensive internal damage to engine.

FUEL SPECIFICATION

1. Follow fueling instruction in the engine manual

⚠ CAUTION ⚠

Handle fuel with care — it is highly flammable. Use only approved fuel container. Never add fuel while engine is running. Fill fuel tank outdoors with extreme care. Never fill fuel tank indoors. Replace gasoline cap securely and wipe up all spilled fuel.

Always clean area around fuel cap before removing it to prevent excessive amounts of dirt from entering fuel system. Also insure that fuel storage container you are using is clean and in good condition.

CORRECT ENGINE OPERATION

⚠ CAUTION ⚠

Before starting engine, become familiar with all controls. Read this Operator's Manual thoroughly. Always check engine oil level before starting engine.

⚠ WARNING ⚠

Care should be taken to avoid inhaling exhaust gasses as they contain carbon monoxide gas which is colorless and odorless. Carbon monoxide is a dangerous gas that can cause unconsciousness and is potentially lethal. Do not run engine in confined areas such as closed garage.

OPERATING YOUR EDGER-TRIMMER

CORRECT ENGINE OPERATION

⚠ CAUTION ⚠

Always disengage edger-trimmer blade and shut engine off when leaving the edger-trimmer unattended, even if for just a few minutes. Prevent accidents; don't give children or unauthorized persons an opportunity to operate this machine.

⚠ CAUTION ⚠

Always start edger-trimmer in motion slowly. Sudden starts can be damaging to the equipment and could cause loss of operator control.

⚠ CAUTION ⚠

Rotating blade can throw dirt or debris. Wear safety glasses when operating the edger-trimmer.

ADJUSTING CUTTERHEAD ANGLE

Before starting engine adjust cutterhead angle. The cutterhead angling lever, located on the left hand side of the frame, enables the operator to position the blade horizontally for trimming or choose several vertical positions for edging.

⚠ WARNING ⚠

Never adjust cutterhead angle when engine is running.

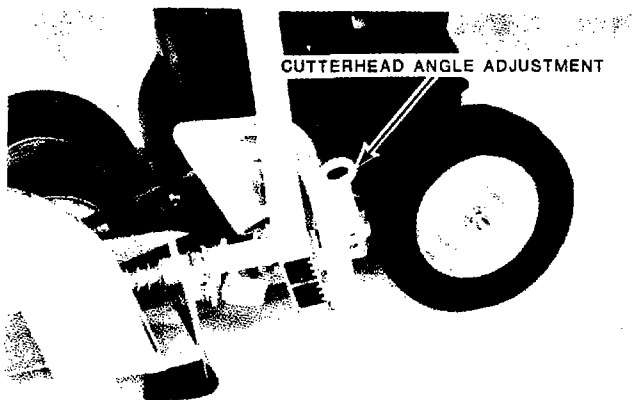

713

Cutterhead Angle Adjustment

CLUTCH AND DEPTH LEVER SETTINGS

Clutch and Depth lever is used to engage and disengage the drive belt which operates the blade. It is also used to regulate the depth of edging and height of trimming.

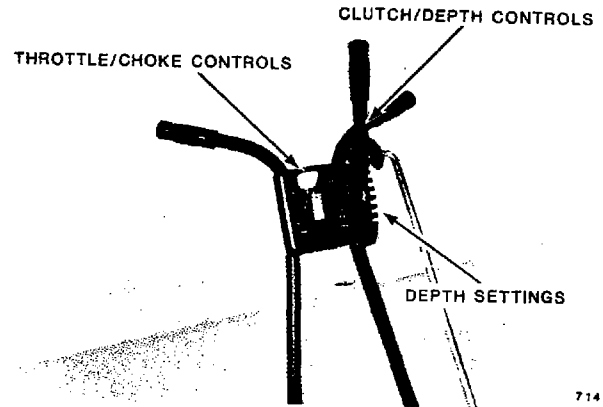

714

Throttle/Choke and
Clutch/Depth Controls.

STARTING THE ENGINE

Be sure the clutch lever is in the rear DISENGAGED position before starting engine.

Manually pull out choke on engine.

Grasp the recoil starting handle and pull quickly. Return the handle slowly. If the engine fails to start after three or four pulls, lower the throttle to the detented full throttle (fast) position.

Once the engine starts, push the choke to the off position. Use the SLOW position to idle the engine.

ENGAGING THE DRIVE BELT

Move clutch and depth lever forward to engage drive belt and blade. Notches in base of lever permit adjusting depth of cut for edging and height for trimming.

TO STOP

Disengage edger trimmer clutch and depth lever.

Move throttle control to stop position. Make sure engine is stopped and blade is not rotating before leaving the operating position.

WHEEL POSITIONING

The wheel adjusting spacer should be centered between the wheels when edging in the vertical position. Wheels must be in the dual position to the right when edging with cutterhead in an angle position or trimming (horizontal position).

⚠ WARNING ⚠

Do not change wheel positions when engine is running.

Remove the spacer from between the wheels by lifting on spacer with open side down. Slide the left front wheel on the axle toward the right wheel and once again install the spacer on the axle between the frame and wheel.

⚠ CAUTION ⚠

Before starting the engine be sure the wheels and cutterhead are positioned so the blade will not strike the wheels.

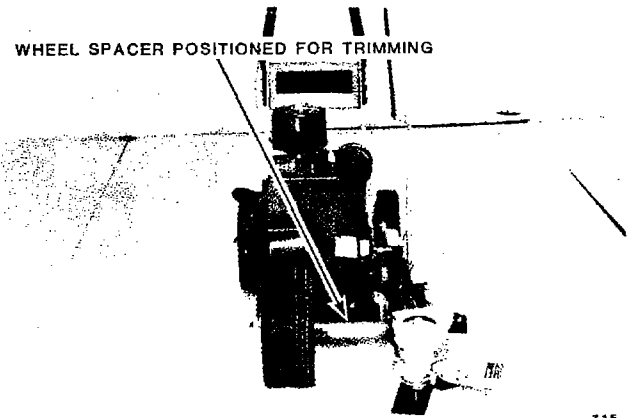

Wheel Positioning

CURB RIDING POSITION

Remove the spacer from between the front wheels. Slide the right wheel toward the left wheel and replace the spacer between the wheel and right frame. Only vertical edging can be done in this position.

NOTE

As pictured above, wheels are positioned to the right for trimming. The wheels are positioned to the left for curb riding edging.

NOTES

CORRECT EDGER-TRIMMER USAGE

⚠ CAUTION ⚠

Read all manuals provided before operating. These manuals give a detailed description of operation and point out other areas of caution. Familiarize yourself thoroughly with equipment before attempting to use it.

OPERATION OF THE EDGER-TRIMMER

⚠ WARNING ⚠

Keep all shields in place. Never attempt to clear discharge areas or edger-trimmer blade without disengaging the edger-trimmer and stopping the engine.

Your edger-trimmer is designed to give a professionally groomed appearance to your lawn with minimum effort. It will edge lawns at walks, around flower beds, trim close to poles and hydrants, also under fences and other hard to reach locations. For best appearance around flowers adjust blade to 20° angle cut.

For best results adjust the cutting depth of the blade to within ½" to 1" deep (with a new blade usually in the third notch of the adjustment bracket at handle).

Too deep a cut will put unnecessary stress on engine and accelerate blade wear. Cutting too shallow allows rapid regrowth of roots.

Make sure to re-adjust cutting depth as blade begins to wear at tips.

Avoid edging or trimming in wet grass as it may clog up in the blade guard and cause splattering. The general appearance will be much better when grass is dry.

Always push edger-trimmer at moderate walking speed — at this speed your edger-trimmer is designed to cut more than 100 ft. per minute. Four wheel design of edger-trimmer permits easy and stable edging, riding securely on sidewalk or cement surfaces.

Around specially shaped flower beds or curved sections follow these simple steps: It will be easier to cut around corners when front wheels are placed together at right side of trimmer-edger. Before starting engine remove wheel spacer clip on front axle, slide wheels to side away from blade and replace spacer.

After starting engine, set blade depth and by slightly lifting rear wheels, guide edger-trimmer around corners and odd angles.

WARNING TO PURCHASERS OF INTERNAL COMBUSTION ENGINE EQUIPPED MACHINERY OR DEVICES

This equipment does not include a spark arrestor muffler.

If this equipment is used on any forest-covered land, brush-covered land or grass-covered land in the State of California, the law requires that a spark arrestor be installed and in effective working order before using this equipment on such land. The spark arrestor must be attached to the exhaust system and comply with Section 4442 of the California Public Resources Code.

If this equipment is used in a state or national park or campground, a U.S.D.A. Forestry Department approved spark arrestor muffler must be utilized.

Two Year Limited Warranty

For two years from purchase (60 days for commercial use) McLane Manufacturing Inc., will replace for the original purchaser, free of charge, any part or parts, found upon examination by any factory authorized service center, or by the factory in Paramount, California, to be defective in material or workmanship or both. All transportation charges on parts submitted for replacement under this warranty must be borne by purchaser. There are no other expressed warranties. Implied warranties, including those of merchantability and fitness for a particular purpose, are limited to two years from purchase and to the extent permitted by law. Any and all implied warranties are excluded. This is the exclusive remedy and liability for consequential damages. Any and all warranties are excluded to the extent exclusion is permitted by law. Some states do not allow limitations on how long an implied warranty lasts, and some states do not allow the exclusion limitation of consequential damages, so the above limitation and exclusion may not apply to you. This warranty gives you specific legal rights and you may also have other rights which vary from state to state.

It is your responsibility to follow the maintenance instructions described in the owner's manual. Routine service (cleaning, blade sharpening) is your responsibility. Defect of engine is covered by manufacturer of engine.

McLane Manufacturing, Inc.

Note: Operator abuse and improper assembly of product is not covered by any written or implied warranty. Read your owner's manual carefully.

MAINTAINING YOUR EDGER-TRIMMER

⚠ CAUTION ⚠

To minimize the chance of injury, perform all maintenance and adjustments on your edger-trimmer with engine off unless instructed otherwise in this section. Use extreme care when working near operating machinery. Do not wear loose fitting clothing. Remove watch and jewelry before beginning work and observe common safety practices when using tools.

MAINTENANCE CHECKLIST

1. Refer to the engine manual for engine maintenance instructions.
2. Correct grade of oil and gasoline is included in the instructions.

Check the oil level of the engine every time the edger-trimmer is used. An improper oil level can cause extensive internal damage to engine.

Failure to change engine oil at recommended intervals can lead to serious damage to engine. This is especially true when using detergent oils which are designed to hold impurities in suspension; when saturation point is reached, oil may suddenly break down to form a gelatin-like substance which seriously impairs and can even stop flow of oil. Increase frequency of oil changes if edger-trimmer is operated under extremely dusty conditions.

SPARK PLUG

Engine misfire, or generally poor operation, is often caused by spark plug in poor condition or with incorrect spark gap setting. Sparkplug should be checked after each fifty hours of operation. Replace a spark plug at one hundred operating hour intervals, or sooner if inspection reveals fouling or excessive deterioration.

Always clean area around spark plug before removing it to prevent dirt from entering engine. Use a spark wrench to remove and install plug.

Check condition of plug. Good operating conditions are indicated by a light coating of grey or tan deposit. A dead white, blistered coating could indicate an "overrich" fuel mixture caused by a clogged air cleaner, or improper carburetor adjustment.

Replace spark plug that is not in good condition. Never sand blast, wire brush, scrape or reinstall spark plug in poor condition. Best results are obtained with a new plug.

Always check spark plug gap before installing a new plug or reinstalling the original plug. Use a spark plug gap gauge to adjust the electrode air gap as indicated in the engine manual.

BLADE MAINTENANCE

⚠ CAUTION ⚠

Sharp edges of edger-trimmer blade can cut you during blade maintenance or adjustment. Use suitable covering over cutting edges of blade to prevent bodily harm.

BLADE CHANGE

1. Place a 5/16" Allen wrench on the inside of cutterhead shaft and a 3/4" wrench on the blade nut, turn to loosen nut. Remove outer washer and old blade.
2. Replace blade with only McLane blade (available in 3-pack). Place outer washer the same direction as removed and tighten nut as snug as possible.

LUBRICATION

1. The cutter head body needs occasional greasing. Use #2 multi-purpose grease.
2. The cutter head mandrel has two precision sealed bearings that do not need lubrication.

USE #2 MULTI-PURPOSE GREASE

GREASE FITTING LOCATION

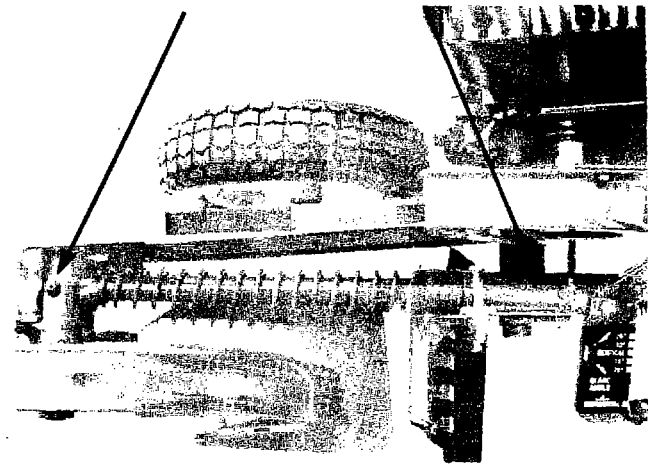

Cutting Head Lubrication Points

Oil all exposed bearings, linkage and front wheels.
check all nuts and bolts for tightness.

Lawn Edger and Trimmer Parts Illustration

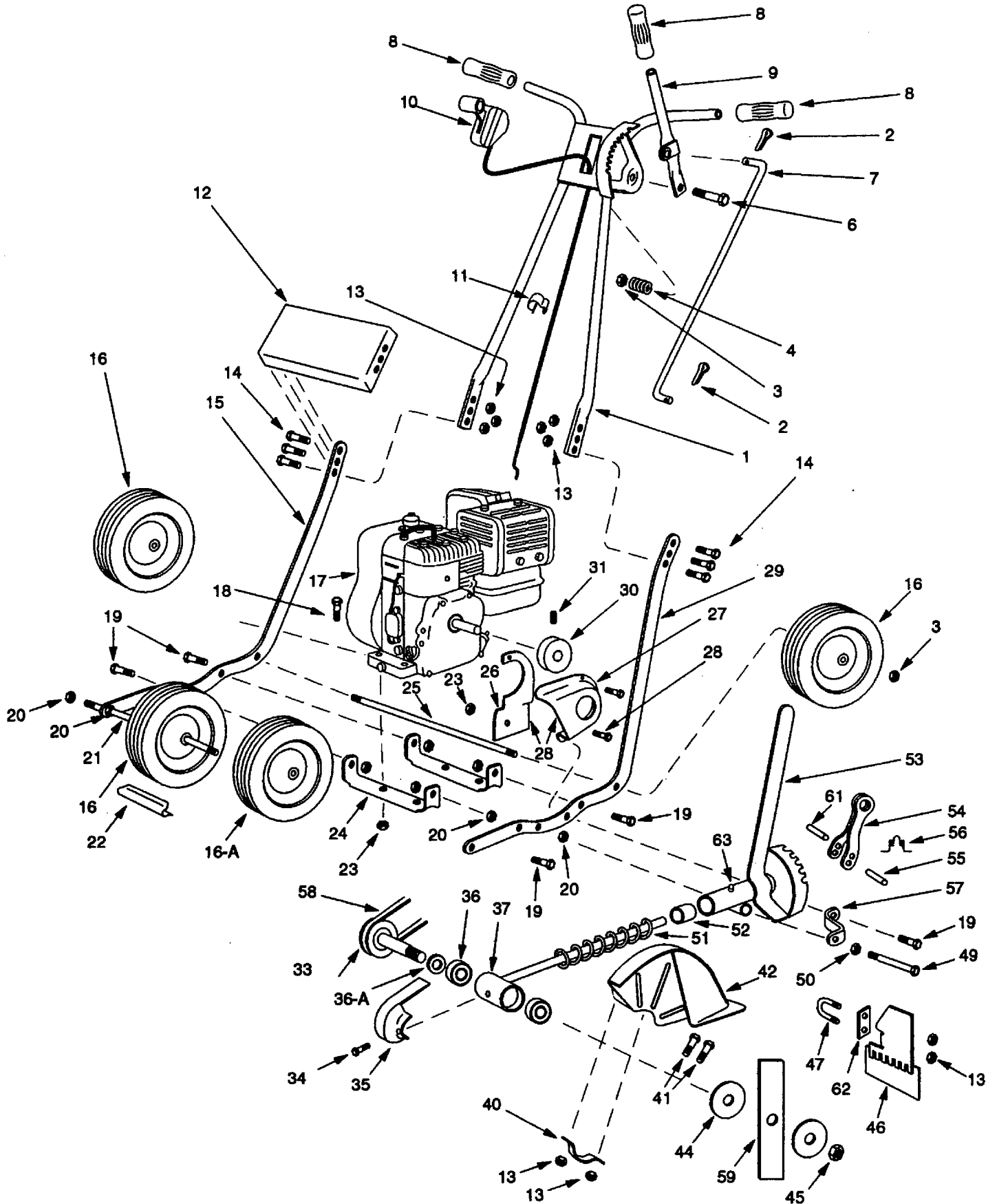



McLane

LAWN EDGER AND TRIMMER PRICE LIST

SUPERSEDES PREVIOUS PRICE LISTS

| REF. No. | PART No. | DESCRIPTION | LIST PRICE | REF. No. | PART No. | DESCRIPTION | LIST PRICE |
|----------|----------|--|------------|----------|----------|---|------------|
| 1 | 2001 | Handle--Until 03/87--After 2/94 | | 27 | 2027 | Guard, Engine Pulley | |
| 1 | 2001-E | Handle--03/87--To 2/94 | | | 2066 | Engine Pulley Guard & Bracket Complete | |
| 2 | 1011 | Pin, Cotter 1/8x3/4" (2 Req) | | 28 | 2028 | Screw, Sheet Metal #10x1/2" (4 Req) | |
| 3 | 1008 | Nut, Lock Hex 7/16"-14 (4 Req) | | 29 | 2029 | 6" & 7" Frame Left Hand | |
| 4 | 2004 | Spring | | 29 | 2029-8 | 8" Frame, Left Hand | |
| 6 | 2006 | Bolt, Hex 7/16"-14x2" | | 30 | 1063 | Engine Pulley | |
| 7 | 2007 | Rod, Clutch & Depth | | 30 | 1063-A | 3/4" Engine Pulley | |
| 8 | 1009 | Grip (3 Req) | | 31 | 1065 | Set Screw 5/16"-24x5/16" | |
| 9 | 2009 | Lever, Clutch & Depth | | 33 | 2033 | Cutterhead Pulley & Shaft Complete | |
| 10 | 1013 | Throttle Control (2HP & 3HP) Length--32-1/4" Prior to 3/87--After2/94 | | 34 | 2034 | Screw, Hex 1/4"-20x1/2" | |
| 10 | 1013-B | Throttle Control (3HP Ball Bearing) Length--40-3/4 Prior to 3/87--After2/94 | | 35 | 2035 | Cutterhead Pulley Guard | |
| 10 | 1013-D | Throttle Control (3HP Ball Bearing) 03/87 to 2/94 | | 36 | 2036 | Cutterhead Bearing (2 Req) | |
| 10 | 1013-E | Throttle Control (2HP & 3HP) 09/87 to 2/94 | | 36A | 2043 | Spring Washer (New 01/87) | |
| 10 | 1013-97 | Throttle Control/Manual Choke After 01/97 | | 37 | 2037 | Mandrel, Head | |
| 10A | 1013-F | Throttle Control Holder--Used w/1013-D & 1013-E | | 40 | 2040 | Clamp, Blade Guard | |
| 11 | 2013-C | Clip Throttle Cable | | 41 | 2041 | Bolt, Hex 1/4"-28x1-1/2" (2 Req) | |
| 12 | 1014 | Cross Brace for Handle | | 42 | 2042 | Blade, Guard Main | |
| 13 | 1015 | Nut Hex 1/4"-28 (10 Req) | | | 2064 | Complete Blade Guard | |
| 14 | 1018 | Bolt Hex 1/4"-28x7/8 (6 Req) | | 44 | 2044 | Washer, Friction (2 Req) | |
| 15 | 2015 | Frame, Right Hand 6" & 7" | | 45 | 2045 | Nut, 1/2"-20 | |
| 15 | 2015-8 | Frame, Right Hand 8" | | 46 | 2046 | Deflector, Debris Sweep | |
| 16 | 2016-6 | Steel Wheel, 6" | | 47 | 2047 | U-Clamp | |
| 16 | 2016-7 | Steel Wheel, 7" | | | 2065 | Complete Debris Guard | |
| 16 | 2016-8 | Steel Wheel, 8" | | 49 | 2049 | Pivot Bolt | |
| 17 | 1043 | Engine (State Model No.) | | 50 | 1120 | Flat Washer7/16" | |
| 18 | 2018 | Bolt 5/16"-24x1-1/2" (4 Req) | | 51 | 2051 | Spring, Head Recoil | |
| 19 | 1074 | Bolt, Hex 5/16"-24x7/8" (5 Req) | | 52 | 2052 | Cup | |
| 20 | 2020 | Nut, Hex 7/16"-14 (3 Req) | | 53 | 2053 | Body, Cutterhead | |
| 21 | 2021 | 6" & 7" Front Axle | | 54 | 2054 | Lever, Angle Shifting | |
| 21 | 2021-8 | 8" Front Axle | | 55 | 2055 | Pin, 5/16"x2" | |
| *22 | 2022-6 | 6" Front Wheel Spacer (3-5/8") | | 56 | 2056 | Spring | |
| *22 | 2022-7 | 7" Front Wheel Spacer (3-1/8") | | 57 | 2057 | Brace Cutterhead | |
| *22 | 2022-8 | 8" Front Wheel Spacer (4-1/4") | | 58 | 2058 | Drive Belt - 4L300 | |
| 23 | 1075 | Nut, Hex 5/16"-24 (9 Req) | | 59 | 2059 | Cutting Blade | |
| 24 | 2024 | 6" & 7" Frame Crossmember | | 61 | 2061 | 1-1/4" Pin | |
| 24 | 2024-8 | 8" Frame Crossmember | | 62 | 2062 | U-Clamp Spacer | |
| 25 | 2025 | 6" Rear Axle | | 63 | 2063 | Grease Fitting | |
| 25 | 2025-7 | 7" Rear Axle | | | 1002 | Handle & Wheel Bearing | |
| 25 | 2025-8 | 8" Rear Axle | | | 2067 | Cutting Head Complete (Includes Part Nos.: 33, 36 (2), 37, 51, 52, 53, 54,55,56, 61,63 (2). | |
| 26 | 2026 | Bracket, Engine Pulley Guard | | | | | |

***FOR EDGERS WITH STEEL WHEELS ONLY.
SEE PAGE 3 FOR WIDE TIRE WHEELS.**

McLane Lawn Edger and Trimmer Parts List (Cont.)

| REF. PART NO. NO. | DESCRIPTION | REF. PART NO. NO. | DESCRIPTION |
|--|--|---|---|
| 2101 REPLACEMENT PARTS | | 7060 | 8" Rear Wheel Inside Bearing Only. Also For 8" Front Wheel. (2 Needed On Front Wheel) |
| 2101-7 | Axle For Edgers With 7" Wheels | 16-A 7075 | 8" Front Wheel Complete w/Bearings & Wide Tire |
| 2101-8 | Axle For Edgers With 8" Wheels | 7061 | 8" Tire Only |
| 2100-A | Plate For 2100 | 7062 | 8" Rear Wheel Rim Only |
| 3066 | Bolt For 2100 (2) | 7065 | 8" Front Wheel Rim Only |
| 1008 | Lock Nut (2) | 22 2022-E | 8" Front Wheel Spacer (2-3/8" Use With 7075 Wheels) |
| 2020 | Nut 7/16"-14 (4) | 22 2022-A | 7" Front Wheel Spacer (2-13/16" Use With 7075-7 Wheels) |
| 1120 | Washer (2) | 25 2025-A | 7" Rear Axle (11-3/8") (Use With 7058-7 Wheels) |
| 7075-7 | Complete Wheel w/Bearings | 25 2025-B | 8" Rear (13-5/8") (Use With 7058 Wheels) |
| 1008 | Jam Nut (2) | | |
| <p>**NOTE: THE 10" HEAVY DUTY EDGER BLADES CAN ONLY BE USED ON McLANE EDGERS ONLY FOR VERTICAL AND ANGLE EDGING. HORIZONTAL TRIMMING MUST NOT BE ATTEMPTED.</p> | | <p>ALL ORDERS UNDER \$15.00 ARE C.O.D.</p> <p><i>When ordering parts, be sure to specify model and part number. Do not order by Ref. No.</i></p> | |
| <p>THE FOLLOWING PARTS ARE ON EDGERS WITH THE NEW WIDE TIRE WHEELS AND PLASTIC WHEEL RIMS. AVAILABLE AS OF MARCH 1986.</p> | | | |
| REF. PART NO. NO. | DESCRIPTION | | |
| 16 7058-7 | 7" Rear Wheel Complete w/Bearings, Wide Tire & Hub Cap | | |
| 16-A 7075-7 | 7" Front Wheel Complete w/Bearings | | |
| 7060 | 7" Wheel Bearing Only (2) | | |
| 7061-7 | 7" Tire Only | | |
| 7062-7 | 7" Rear Wheel Rim Only | | |
| 7065-7 | 7" Front Wheel Rim Only | | |
| 7063 | Hub Cap For 7" & 8" Rear Wheels | | |
| 16 7058 | 8" Rear Wheel Complete w/Bearings, Wide Tire & Hub Cap | | |
| 7059 | 8" Rear Wheel Outside Bearing Only | | |

TROUBLE SHOOTING CHART

| PROBLEM | CAUSE |
|--|---|
| 1 Engine fails to start. | <p>A Check fuel tank for gas.</p> <p>B Spark plug lead wire disconnected.</p> <p>C Throttle control lever not in starting position.</p> <p>D Check spark plug.*</p> <p>E Carburetor improperly adjusted. Engine flooded. Remove spark plug, dry the plug, crank engine with plug removed, and throttle in off position. Replace spark plug and lead wire and resume starting procedures.</p> <p>F Old/stale gas. Drain and refill with fresh gas.</p> |
| 2 Hard starting or loss of power. | <p>A Spark plug wire loose.</p> <p>B Carburetor improperly adjusted.*</p> <p>C Dirty air cleaner.*</p> |
| 3 Operation erratic. | <p>A Dirt in gas tank. Drain, clean and refill.</p> <p>B Dirty air cleaner.*</p> <p>C Water in fuel supply. Drain and refill.</p> <p>D Vent in gas cap and/or carburetor plugged. Clear vent.</p> <p>E Carburetor improperly adjusted.*</p> |
| 4 Occasional skip (hesitates) at high speed. | <p>A Spark plug fouled, faulty or gap too wide.*</p> <p>B Carburetor improperly adjusted.*</p> <p>C Dirty air cleaner.*</p> |
| 5 Idles poorly. | <p>A Carburetor idle speed too slow.*</p> <p>B Spark plug gap too close.*</p> <p>C Carburetor idle mixture adjustment improperly set.*</p> |
| 6 Engine overheats. | <p>A Adjust carburetor.*</p> <p>C Remove any obstructions from air passages in shrouds.</p> <p>B Clean cooling fins.</p> <p>D Fill crankcase to proper oil level.</p> |

***Note:** For repairs beyond the minor adjustments listed above, please contact your local Lawn Mower Service Shop.

STORAGE INSTRUCTIONS

Edger trimmers stored for any length of time should be completely drained of fuel to prevent gum deposits forming on essential parts such as the carburetor and fuel tank. such deposits may effect the operation of the engine when used again. Therefor, it is important that the following instructions be adhered to before starting engine. 1. Drain fuel tank completely. 2. Operate the engine until it stops from lack of fuel to clean all gasoline out of carburetor. 3. While engine is still warm, drain the crank case. Refill with fresh oil. 4. Remove spark plug, poor one ounce of oil into the cylinder. Pull starter rope on the engine to spread the oil. Replace spark plug. 5. Clean dirt and chaff from cylinder and cylinder head fins, blower housing etc.

MAINTENANCE NOTES



Maintenance Notes